

Installation Note

Add 4-Port Capability Upgrade Kit

To Upgrade PNA-X N5241A or N5242A Option 219 to Option 419

Upgrade Kit Order Numbers: N5241AU- 942 and N5242AU- 942



Agilent Kit Number: N5242-60108
Agilent Document Number: N5242-90016
Printed in USA January 19, 2010
Supersedes: September 10, 2009

© Agilent Technologies, Inc. 2009–2010



N5242-90016

WARRANTY STATEMENT

THE MATERIAL CONTAINED IN THIS DOCUMENT IS PROVIDED “AS IS,” AND IS SUBJECT TO BEING CHANGED, WITHOUT NOTICE, IN FUTURE EDITIONS. FURTHER, TO THE MAXIMUM EXTENT PERMITTED BY APPLICABLE LAW, AGILENT DISCLAIMS ALL WARRANTIES, EITHER EXPRESS OR IMPLIED WITH REGARD TO THIS MANUAL AND ANY INFORMATION CONTAINED HEREIN, INCLUDING BUT NOT LIMITED TO THE IMPLIED WARRANTIES OF MERCHANTABILITY AND FITNESS FOR A PARTICULAR PURPOSE. AGILENT SHALL NOT BE LIABLE FOR ERRORS OR FOR INCIDENTAL OR CONSEQUENTIAL DAMAGES IN CONNECTION WITH THE FURNISHING, USE, OR PERFORMANCE OF THIS DOCUMENT OR ANY INFORMATION CONTAINED HEREIN. SHOULD AGILENT AND THE USER HAVE A SEPARATE WRITTEN AGREEMENT WITH WARRANTY TERMS COVERING THE MATERIAL IN THIS DOCUMENT THAT CONFLICT WITH THESE TERMS, THE WARRANTY TERMS IN THE SEPARATE AGREEMENT WILL CONTROL.

DFARS/Restricted Rights Notice

If software is for use in the performance of a U.S. Government prime contract or subcontract, Software is delivered and licensed as “Commercial computer software” as defined in DFAR 252.227-7014 (June 1995), or as a “commercial item” as defined in FAR 2.101(a) or as “Restricted computer software” as defined in FAR 52.227-19 (June 1987) or any equivalent agency regulation or contract clause. Use, duplication or disclosure of Software is subject to Agilent Technologies’ standard commercial license terms, and non-DOD Departments and Agencies of the U.S. Government will receive no greater than Restricted Rights as defined in FAR 52.227-19(c)(1-2) (June 1987). U.S. Government users will receive no greater than Limited Rights as defined in FAR 52.227-14 (June 1987) or DFAR 252.227-7015 (b)(2) (November 1995), as applicable in any technical data.

Safety Notes

The following safety notes are used throughout this document. Familiarize yourself with each of these notes and its meaning before performing any of the procedures in this document.

WARNING	Warning denotes a hazard. It calls attention to a procedure which, if not correctly performed or adhered to, could result in injury or loss of life. Do not proceed beyond a warning note until the indicated conditions are fully understood and met.
----------------	---

CAUTION	Caution denotes a hazard. It calls attention to a procedure that, if not correctly performed or adhered to, could result in damage to or destruction of the instrument. Do not proceed beyond a caution sign until the indicated conditions are fully understood and met.
----------------	---

Description of the Upgrade

This upgrade converts your N5241A or N5242A Option 219 2-port analyzer to a N5241A or N5242A Option 419 4-port analyzer by adding:

- an additional 26.5 GHZ source board
- an additional 13.5 GHZ source synthesizer board
- an additional mixer brick
- two additional bridges
- two additional couplers
- two additional bias tees
- two additional source attenuators
- two additional receiver attenuators
- a splitter
- a modified front panel, including 2 new test ports
- many new cables

Getting Assistance from Agilent

Installing this upgrade kit requires special skills and experience. If you think you may not be qualified to do the work, or need advice, contact Agilent.

Contacting Agilent

Assistance with test and measurements needs and information on finding a local Agilent office are available on the Web at:

<http://www.agilent.com/find/assist>

If you do not have access to the Internet, please contact your Agilent field engineer.

NOTE	In any correspondence or telephone conversation, refer to the Agilent product by its model number and full serial number. With this information, the Agilent representative can determine whether your product is still within its warranty period.
-------------	---

Getting Prepared

To successfully install this upgrade kit, you will need the following:

- A license key - refer to “[License Key Redemption](#)” below.
- A PDF copy or a paper copy of the PNA Service Guide - refer to “[Downloading the Online PNA Service Guide](#)” below.
- An ESD-safe work area - refer to “[Protecting Your Workspace from Electrostatic Discharge](#)” below.
- Correct tools - refer to “[Tools Required for the Installation](#)” on page 5.
- Enough time - refer to “[About Installing the Upgrade](#)” on page 6.
- Test equipment for the post-upgrade adjustments. To view the equipment list, click the Chapter 3 bookmark “Tests and Adjustments” in the PDF Service Guide¹.

License Key Redemption

NOTE The enclosed Option Entitlement Certificate is a receipt, verifying that you have purchased a licensed option for the PNA of your choice. You must now use an Agilent Web page to request a license key for the instrument that will receive the option.

To enable the option product, you must request a license key from: <http://www.agilent.com/find/softwarelicense>. To complete the request, you will need to gather the following information:

- From the certificate
 - Order number
 - Certificate number
- From your instrument
 - Model number
 - Serial number
 - Host ID

The instrument information is available on the network analyzer – on the analyzer’s **Help** menu, click **About Network Analyzer**.

If you provide an email address, Agilent will promptly email your license key. Otherwise, you will receive your license key via postal mail.

1. See “[Downloading the Online PNA Service Guide](#)” on page 5.

Downloading the Online PNA Service Guide

To view the online Service Guide for your PNA model number, use the following steps:

1. Go to www.agilent.com.
2. In the Search box, enter the model number of the analyzer (Ex: N5242A) and click **Search**.
3. Click [Technical Support > Manuals](#).
4. Click [Service Manual](#).
5. Click the service guide title to download the PDF file.
6. When the PDF of the Service Guide is displayed, scroll through the Contents section bookmarks to locate the information needed.

Protecting Your Workspace from Electrostatic Discharge

For information, click on the Chapter 1 bookmark, “Electrostatic Discharge Protection” in the PDF Service Guide¹.

ESD Equipment Required for the Installation

Description	Agilent Part Number
ESD grounding wrist strap	9300-1367
5-ft grounding cord for wrist strap	9300-0980
2 x 4 ft conductive table mat and 15-ft grounding wire	9300-0797
ESD heel strap (for use with conductive floors)	9300-1308

Tools Required for the Installation

Description	Qty	Part Number
T-10 TORX driver - set to 9 in-lbs (1.02 N.m)	1	N/A
T-20 TORX driver - set to 21 in-lbs (2.38 N.m)	1	N/A
5/16-in (8 mm) nutsetter or open end torque wrench- set to 10 in-lbs (1.13 N.m)	1	N/A
5/16-in (8 mm) nutsetter or open end torque wrench - set to 21 in-lbs (2.38 N.m)	1	N/A
3/16-in (5 mm) nutsetter or open end torque wrench - set to 6 in-lbs (0.68 N.m)	1	N/A
5/8-in (16 mm) nutsetter or open end torque wrench - set to 21 in-lbs (2.38 N.m)	1	N/A
1-in (25.4 mm) torque wrench - set to 72 in-lbs (8.15 N.m)	1	N/A
1/4-in (6 mm) open end wrench	1	N/A

CAUTION Use a 5/16-in torque wrench set to 10 in-lbs on all cable connections except the front and rear panel cable connectors. Torque these connections to 21 in-lb.

About Installing the Upgrade

Products affected.	N5241A or N5242A Option 219
Installation to be performed by	Agilent service center or personnel qualified by Agilent
Estimated installation time	5 hours
Estimated adjustment time	0.5 hour
Estimated full instrument calibration time	4.5 hours

Items Included in the Upgrade Kit

Check the contents of your kit against the following list. If any part is missing or damaged, contact Agilent Technologies. Refer to [“Getting Assistance from Agilent” on page 3](#).

Table 1 Contents of Upgrade Kit N5242-60108

Ref Desig.	Description	Qty	Part Number
-	Installation note (this document)	1	N5242-90016
A8	26.5 GHz source 2 board	1	5087-7307
A13	13.5 GHz source 2 synthesizer board	1	N5230-60002
A22	Splitter	1	5087-7139
A24	Mixer brick 2	1	5087-7722
A26	Test port 3 bridge	2	5087-7315
A27	Test port 4 bridge		
A30	Test port 3 coupler	2	5087-7710
A31	Test port 4 coupler		
A35	Test port 3 source attenuator	2	33321-60070
A36	Test port 4 source attenuator		
A39	Test port 3 bias tee (includes wire harness)	2	5087-7781
A40	Test port 4 bias tee (includes wire harness)		
A43	Test port 3 receiver attenuator	2	33321-60066
A44	Test port 4 receiver attenuator		
-	Machine screw, M3.0 x 20, pan head (3 to attach mixer brick 2 to mounting block; 4 to attach 2 bridges to brackets)	7	0515-1410
-	Machine screw, M3.0 x 8, pan head (2 to attach mixer brick 2 to mounting block; 8 to attach 2 src attn. and 2 rcvr attn. to brackets)	10	0515-0372
-	Machine screw, M3.0 x 6, pan head (4 to attach 2 bridges to deck; 6 to attach 2 attn. assy. to deck)	10	0515-0430
-	Machine screw, M3.0 x 14, pan head (4 to attach 2 bias tees to brackets)	4	0515-0665
-	Machine screw, M4 x 10, pan head (to attach A8 source 2 board to A19 motherboard)	2	0515-0380
-	Front frame, 1-piece, machined, 4-port	1	N5245-20128
-	Lower front panel overlay, 4-port (all instruments without Option 029)	1	N5242-80003
-	Keypad overlay	1	N5242-80005
-	Power switch overlay	1	N5242-80007
-	Nameplate, N5241A	1	N5241-80001
-	Nameplate, N5242A	1	N5242-80006
-	Test set front sub panel, 4-port	1	N5242-00003
-	Gap pad (between each coupler and test set front sub panel)	4	E4403-20033
-	Vibration mount (between couplers 1 & 3, and 2 & 4)	2	0460-2725
-	Mounting nuts (for port 3 & 4 test port couplers)	2	5022-1087

Table 1 Contents of Upgrade Kit N5242-60108

Ref Desig.	Description	Qty	Part Number
-	Short (for Mixer Brick A24) (NOT for option 029)	1	0960-0055
-	Cable guard	1	N5242-00030
-	Tie wrap, 1 to secure N5242-20048 and 3 to secure N5242-20009 cable to side of deck	4	1400-0249
-	Bracket for test port bridge	2	N5242-00006
-	Bracket for source and receiver attenuator	2	N5242-00007
W2	A13 13.5 GHz source 2 synth board J1207 to A8 26.5 GHz source 2 board P1	1	N5242-20124
W5	A8 source 2 to W6	1	N5242-20091
W6	W5 to A26 port 3 bridge	1	N5242-20051
W7	A8 source 2 to W8	1	N5242-20092
W8	W7 to A27 port 4 bridge	1	N5242-20052
W14	A29 port 1 coupler to front-panel Port 1 CPLR ARM	1	N5242-20040
W17	A26 port 3 bridge to front-panel REF 3 SOURCE OUT	1	N5242-20033
W18	A30 port 3 coupler to front-panel Port 3 CPLR ARM	1	N5242-20025
W21	A27 port 4 bridge to front-panel REF 4 SOURCE OUT	1	N5242-20035
W22	A31 port 4 coupler to front-panel Port 4 CPLR ARM	1	N5242-20028
W26	A32 port 2 coupler to front-panel Port 2 CPLR ARM	1	N5242-20044
W30	Front panel jumpers	6	E8356-20072
W38	REF 3 RCVR R3 IN to A24 mixer brick (R3)	1	N5242-20034
W39	REF 4 RCVR R4 IN to A24 mixer brick (R4)	1	N5242-20037
W42	A21 HMA26.5 to A22 splitter	1	N5242-20015
W43	A22 splitter to A23 mixer brick	1	N5242-20013
W44	A22 splitter to A24 mixer brick	1	N5242-20014
W52	A23 mixer brick (R1) to A20 IF multiplexer (P411)	1	N5242-60021
W53	A23 mixer brick (R2) to A20 IF multiplexer (P412)	1	N5242-60022
W55	A24 mixer brick (D) to A20 IF multiplexer (P801)	1	N5242-60024
W56	A24 mixer brick (R4) to A20 IF multiplexer (P414)	1	N5242-60019
W57	A24 mixer brick (R3) to A20 IF multiplexer (P413)	1	N5242-60020
W58	A24 mixer brick (C) to A20 IF multiplexer (P601)	1	N5242-60023
W67	A10 frequency reference board J7 to A13 13.5 GHz source 2 synth board J5	1	N5242-60030
W74	A38 port 1 bias tee to A29 port 1 coupler	1	N5242-20022
W75	A26 port 3 bridge to A35 port 3 source attenuator	1	N5242-20005
W76	A35 port 3 source attenuator to front-panel Port 3 SOURCE OUT	1	N5242-20029
W77	Port 3 CPLR THRU to A39 port 3 bias tee	1	N5242-20026
W78	A39 port 3 bias tee to A30 port 3 coupler	1	N5242-20021
W79	A27 port 4 bridge to A36 port 4 source attenuator	1	N5242-20002
W80	A36 port 4 source attenuator to front-panel Port 4 SOURCE OUT	1	N5242-20030

Table 1 Contents of Upgrade Kit N5242-60108

Ref Desig.	Description	Qty	Part Number
W81	Port 4 CPLR THRU to A40 port 4 bias tee	1	N5242-20027
W82	A40 port 4 bias tee to A31 port 4 coupler	1	N5242-20024
W86	A41 port 2 bias tee to A32 port 2 coupler	1	N5242-20023
W89	Port 3 RCVR C IN to A43 port 3 receiver attenuator	1	N5242-20031
W90	A43 port 3 receiver attenuator to A24 mixer brick (C)	1	N5242-20012
W91	Port 4 RCVR D IN to A44 port 4 receiver attenuator	1	N5242-20032
W92	A44 port 4 receiver attenuator to A24 mixer brick (D)	1	N5242-20036
-	Ribbon cable, A19 test set motherboard J202 to A35 port 3 source attenuator	2	N5242-60008
-	Ribbon cable, A19 test set motherboard J203 to A36 port 4 source attenuator		
-	Ribbon cable, A19 test set motherboard J206 to A43 port 3 receiver attenuator	2	N5242-60007
-	Ribbon cable, A19 test set motherboard J207 to A44 port 4 receiver attenuator		
-	Ribbon cable, A19 test set motherboard J213 to A24 mixer brick 2	1	N5242-60006
A PNA Option 219 with Option 029 being upgraded to Option 419 with Option 029 will require the items previously listed and the following items also.			
-	Lower front panel overlay, 4-port (all options with 029)	1	N5242-80012
W140	A24 mixer brick to A55 noise downconverter	1	N5242-20118

Installation Procedure for the Upgrade

The network analyzer must be in proper working condition prior to installing this option. Any necessary repairs must be made before proceeding with this installation.

WARNING **This installation requires the removal of the analyzer's protective outer covers. The analyzer must be powered down and disconnected from the mains supply before performing this procedure.**

Overview of the Installation Procedure

Step 1. Obtain a Keyword and Verify the Information.

Step 2. Remove the Outer Cover.

Step 3. Remove the Inner Cover.

Step 4. Remove the Front Panel Assembly.

Step 5. Remove the A19 Test Set Motherboard.

Step 6. Remove Some Existing Semirigid Test Set Cables.

Step 7. Remove the A23 Mixer Brick Assembly.

Step 8. Assemble the A24 Mixer Brick and A22 Splitter.

Step 9. Assemble the A26 and A27 Test Port Bridges.

Step 10. Install the Mixer Bricks Assembly and Test Port Bridge Assemblies.

Step 11. Assemble the A35 and A36 Source Attenuators and the A43 and A44 Receiver Attenuators.

Step 12. Install the Bias Tees and the Attenuator Assemblies.

Step 13. Assemble the A29 - A32 Test Port Coupler Assemblies.

Step 14. Install the LED Boards and Test Port Coupler Assemblies to the Test Set Front Plate.

Step 15. Install the Coupler Plate Assembly to the Deck.

Step 16. Install the Second Source Boards.

Step 17. Install the Test Set Cables.

Step 18. Secure the Front Panel Bulkhead Connectors.

Step 19. Reinstall the A19 Test Set Motherboard.

Step 20. Replace the 2-Port Front Frame with a 4-Port Front Frame.

Step 21. Reinstall the Front Panel Assembly.

Step 22. Install the Front Panel Overlays.

Step 23. Install the Front Panel Jumper Cables.

Step 24. Reinstall the Inner Cover.

Step 25. Reinstall the Outer Cover.

[Step 26. Install the Cable Guard.](#)

[Step 27. Enable Options P04 and 419.](#)

[Step 28. Perform Post-Upgrade Adjustments and Calibration.](#)

Step 1. Obtain a Keyword and Verify the Information

Follow the instructions on the Option Entitlement Certificate supplied to obtain a license key for installation of this upgrade. Refer to [“License Key Redemption” on page 4](#).

Verify that the model number, serial number, and option number information on the license key match those of the instrument on which this upgrade will be installed.

If the model number, serial number, or option number do not match those on your license key, you will not be able to install the option. If this is the case, contact Agilent for assistance before beginning the installation of this upgrade. Refer to [“Contacting Agilent” on page 3](#).

Once the license key has been received and the information verified, you can proceed with the installation at step 2.

Step 2. Remove the Outer Cover

For instructions, click the Chapter 7 bookmark “Removing the Covers” in the PDF Service Guide¹.

Step 3. Remove the Inner Cover

For instructions, click the Chapter 7 bookmark “Removing the Covers” in the PDF Service Guide¹.

Step 4. Remove the Front Panel Assembly

For instructions, click the Chapter 7 bookmark “Removing and Replacing the Front Panel Assembly” in the PDF Service Guide¹.

Step 5. Remove the A19 Test Set Motherboard

For instructions, click the Chapter 7 bookmark “Removing and Replacing the A19 Test Set Motherboard” in the PDF Service Guide¹.

1. See [“Downloading the Online PNA Service Guide” on page 5](#).

Step 6. Remove Some Existing Semirigid Test Set Cables

CAUTION Be careful not to damage the center pins of the semirigid cables. Some flexing of the cables may be necessary but do not over-bend them.

1. Place the analyzer bottom-side up on a flat surface.
2. Remove all bottom-side semirigid cables except for those in the table below. To see an image showing the location of these cables, click the Chapter 6 bookmark “Bottom RF Cables, 2-Port, Option 219” in the PDF Service Guide¹. Do not discard the cables because some will be reused later in the procedure.

Reference Designator	Type ^a	Part Number	Qty	Description
W3	SR	N5242-20091	1	A5 source (1) to W4
W9	SR	N5242-20092	1	A5 source (1) to W10
W45	SR	N5242-20093	1	A5 source (1) to W46
W46	SR	N5242-20090	1	W46 to rear-panel EXT TSET DRIVE RF OUT (J6)
W47	SR	N5242-20089	1	A23 mixer brick to EXT TSET DRIVE LO OUT (J5)
Option 029 only:				
W131	SR	1250-3576	1	Adapter, coax, straight, m-m, 50 ohm
W141	SR	N5242-20129	1	A55 noise downconverter to A7 noise receiver board LO
W143	SR	N5242-20130	1	A55 noise downconverter to A7 noise receiver board RF

a. SR = semirigid coaxial cable.

3. Leave the gray flexible cables, the wire harnesses, and the ribbon cables connected where possible. Any that are removed should be labeled for reconnection later.

Step 7. Remove the A23 Mixer Brick Assembly

Remove the A23 mixer brick assembly from the PNA. For instructions, click the Chapter 7 bookmark, “Removing and Replacing the A23 and A24 Mixer Bricks” in the PDF Service Guide¹.

Step 8. Assemble the A24 Mixer Brick and A22 Splitter

Refer to [Figure 1](#) in this document for this step. New parts are listed in [Table 1 on page 7](#) of this document.

1. Install the A24 mixer brick (5087-7722) to the mounting block by hand-starting three screws (item ①; 0515-1410). Do not tighten.
2. Install two screws (item ②; 0515-0372) and torque to 9 in-lbs.
3. Go back and torque the three screws (item ①; 0515-1410) to 9 in-lbs.

Figure 1 A24 Mixer Brick Assembly

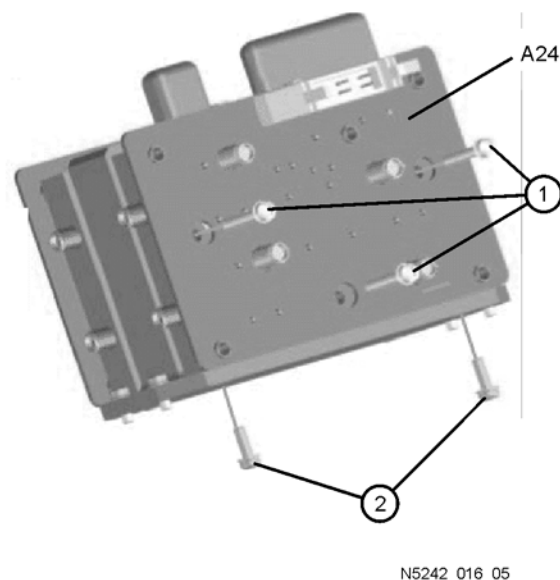

1. See [“Downloading the Online PNA Service Guide” on page 5](#).

Refer to [Figure 2](#) in this document for the remainder of this step.

- Follow the eleven instructions shown in [Figure 2](#). If the PNA does include Option 029, omit instruction 2 and the unnumbered instruction to install a splitter - it is already installed. New parts are listed in [Table 1 on page 7](#) of this document.

NOTE Graphics in this document such as [Figure 2](#) use very brief text to instruct where to connect a cable. For example, text that reads “N5242-60018 IFMUX P201 - BRK1 B” means to connect the N5242-60018 gray flexible cable at the A20 IF MUX board connector P201 and at A23 Mixer Brick 1 connector B.

Figure 2 A23 and A24 Mixer Brick Assembly

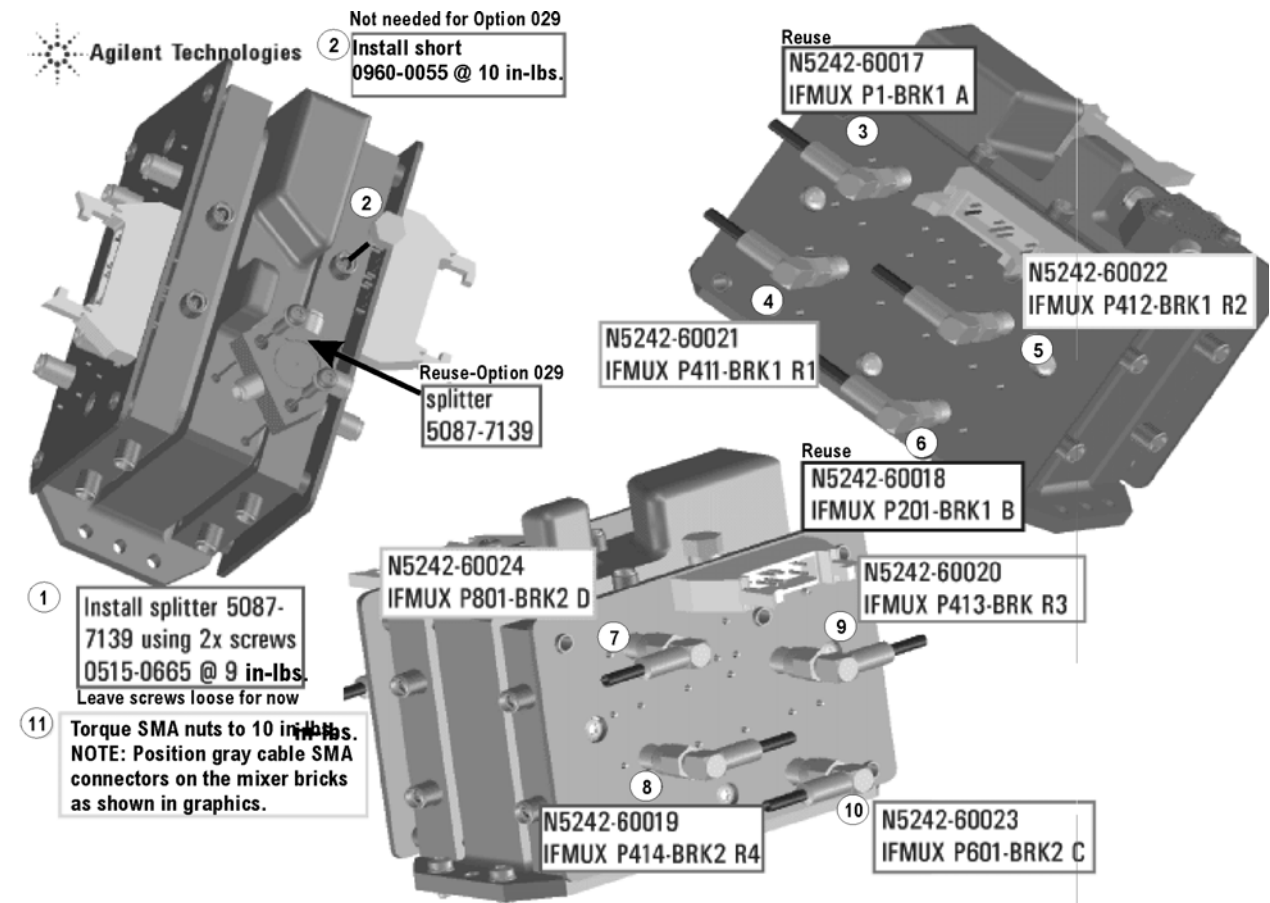

N5242_016_06

Step 9. Assemble the A26 and A27 Test Port Bridges

Follow the two instructions shown in [Figure 3](#).

Figure 3 A26 and A27 Test Port Bridge Assembly

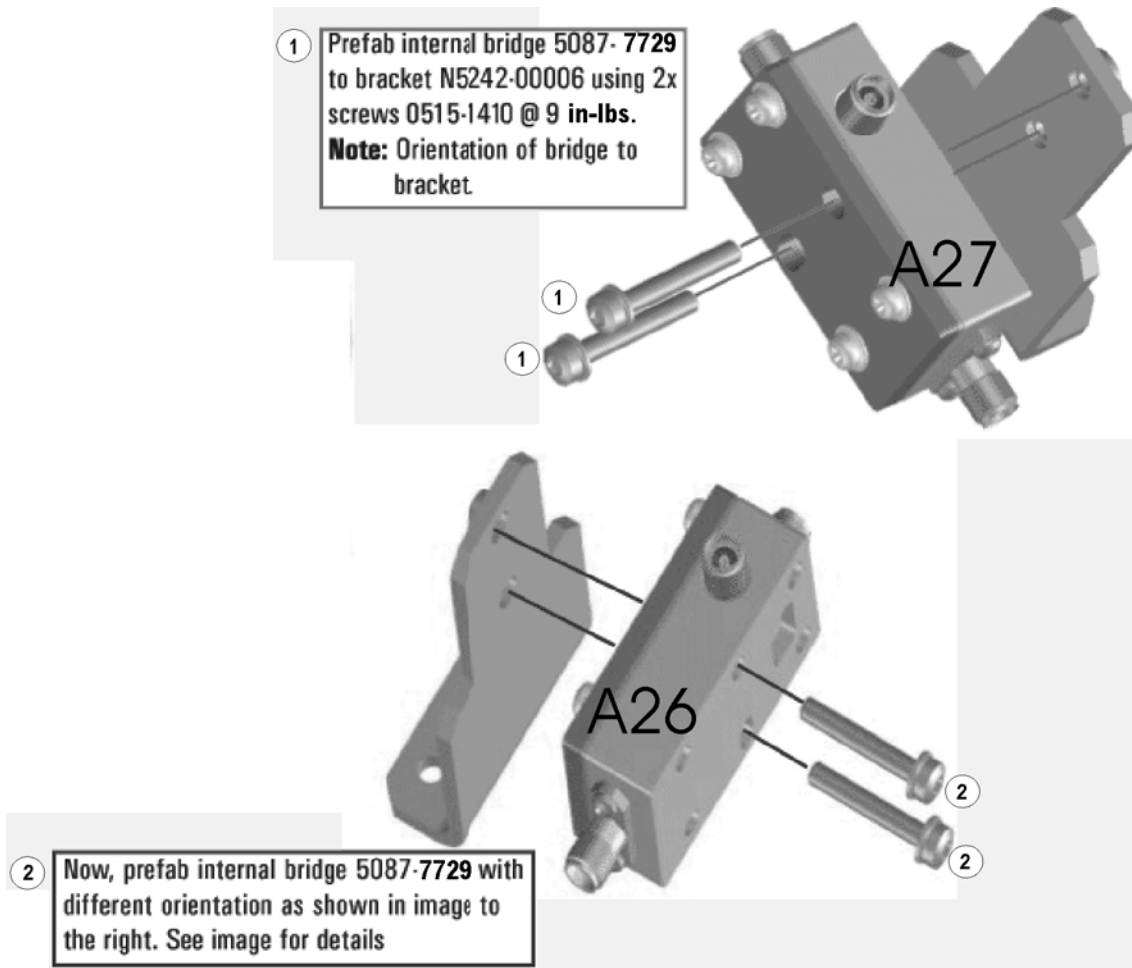

N5242_016_07

Step 10. Install the Mixer Bricks Assembly and Test Port Bridge Assemblies

Follow the two instructions shown in [Figure 4](#).

Figure 4 A23, A24 Mixer Bricks Installation and A26, A27 Test Port Bridges Installation

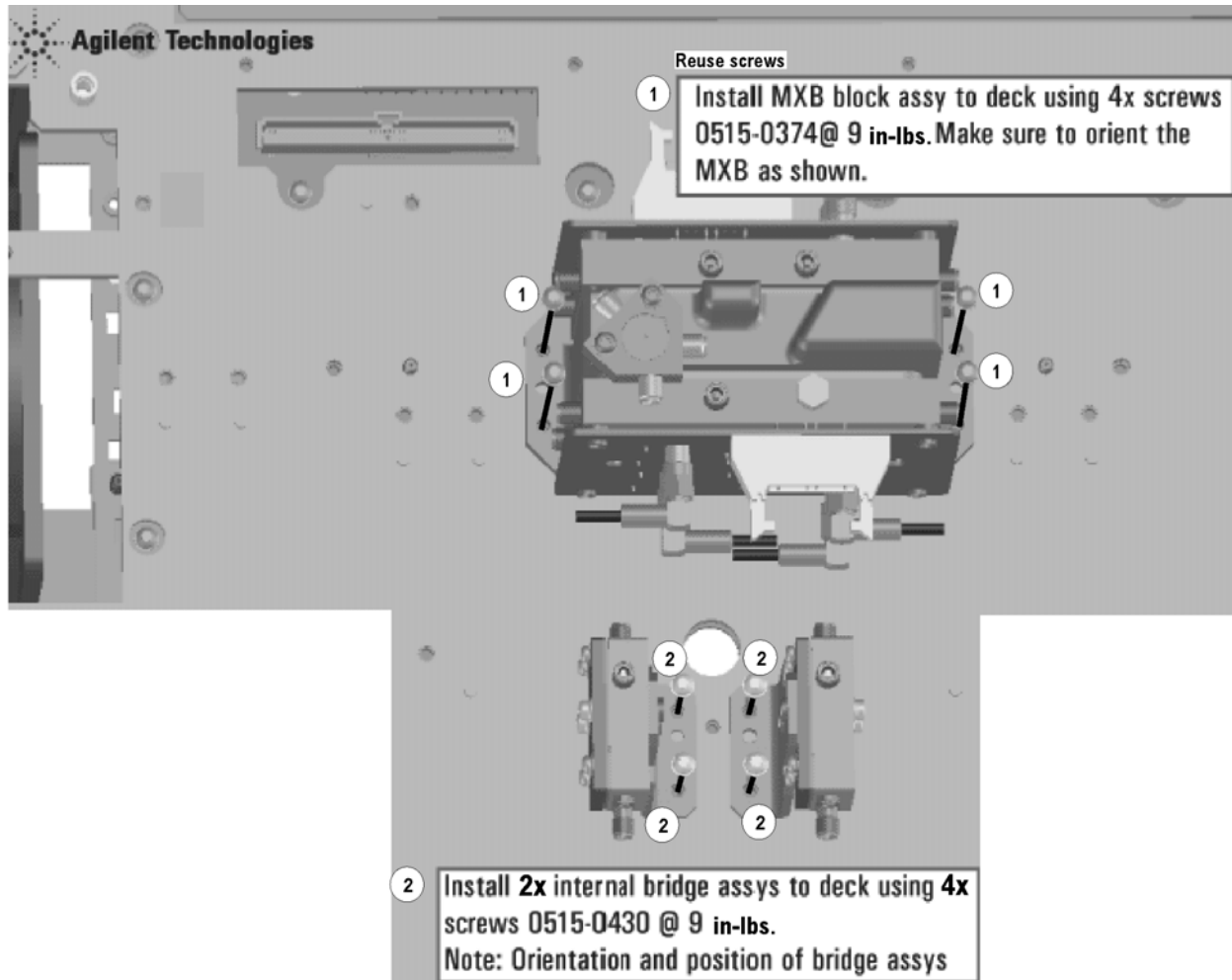

N5242_016_08

Step 11. Assemble the A35 and A36 Source Attenuators and the A43 and A44 Receiver Attenuators

Follow the five instructions shown in [Figure 5](#).

Figure 5 A35, A36 Source Attenuators Assembly and A43, A44 Receiver Attenuators Assembly

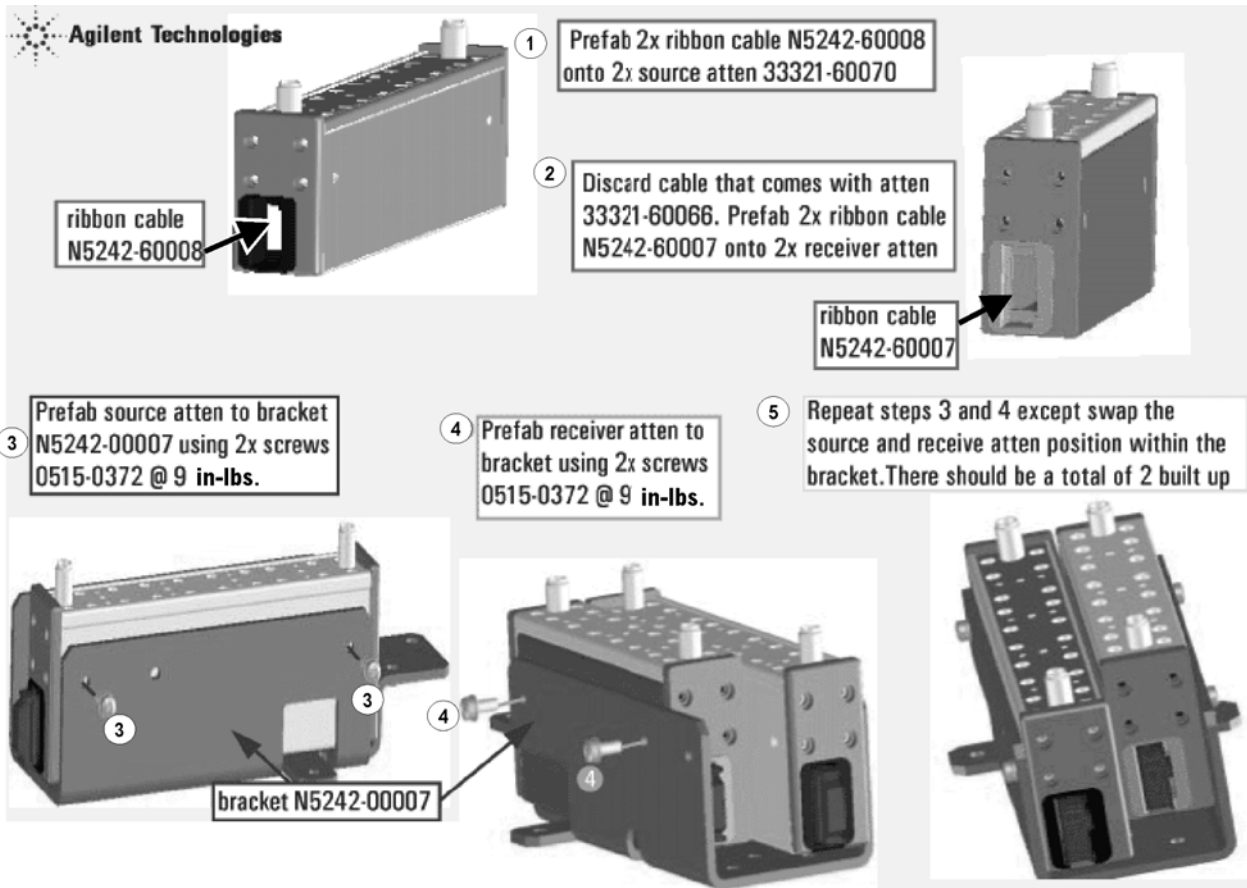

N5242_016_09

Step 12. Install the Bias Tees and the Attenuator Assemblies

Follow the two instructions shown in [Figure 6](#).

Figure 6 Bias Tees and Attenuators Installation

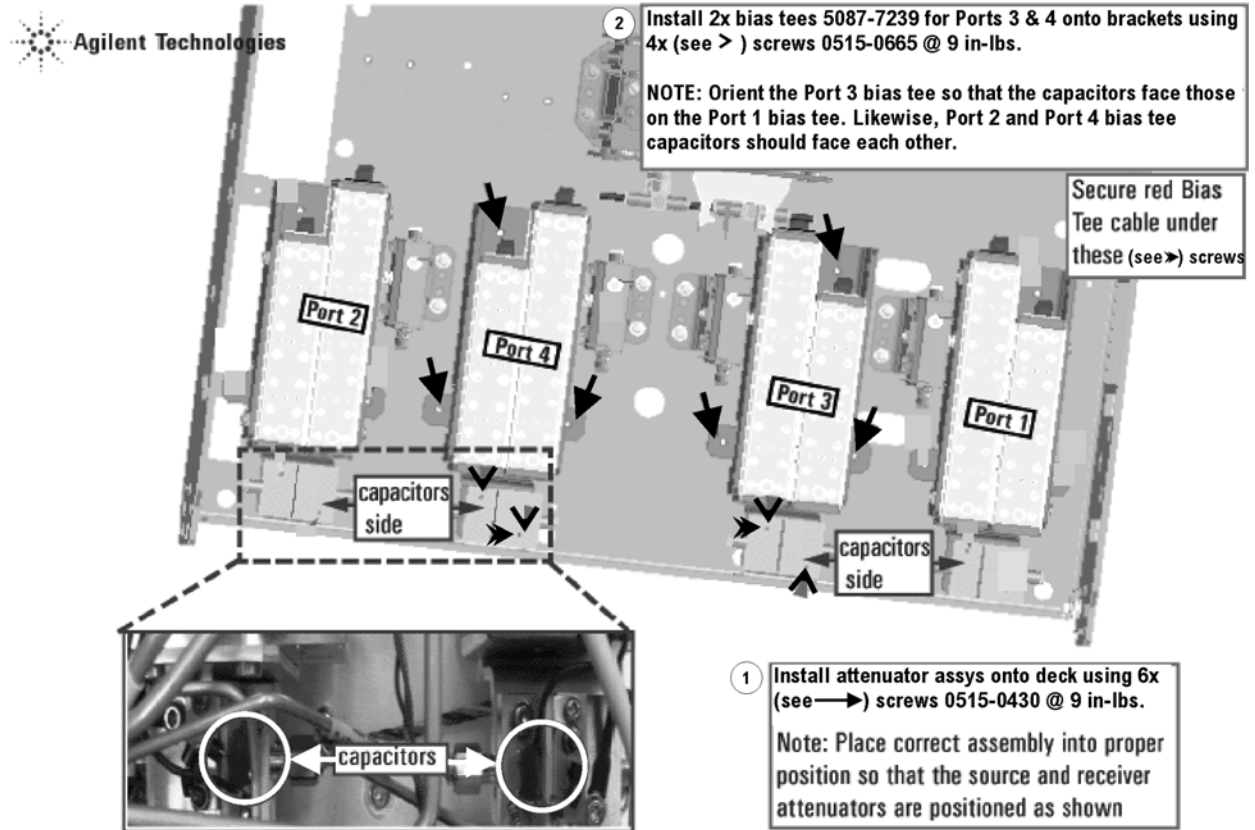

N5242_016_10

Step 13. Assemble the A29 - A32 Test Port Coupler Assemblies

1. Remove the A29 test port 1 coupler and A32 test port 2 coupler from the PNA. For instructions, click the Chapter 7 bookmark, “Removing and Replacing the A29 - A32 Test Port Couplers” in the PDF Service Guide¹.
2. Using pliers, remove the adhesive bumper on the A29 test port 1 coupler and on the A32 test port 2 coupler.
3. Follow the two instructions shown in [Figure 7](#). New parts are listed in [Table 1 on page 7](#) of this document.

Figure 7 A29 - A32 Test Port Coupler Assembly

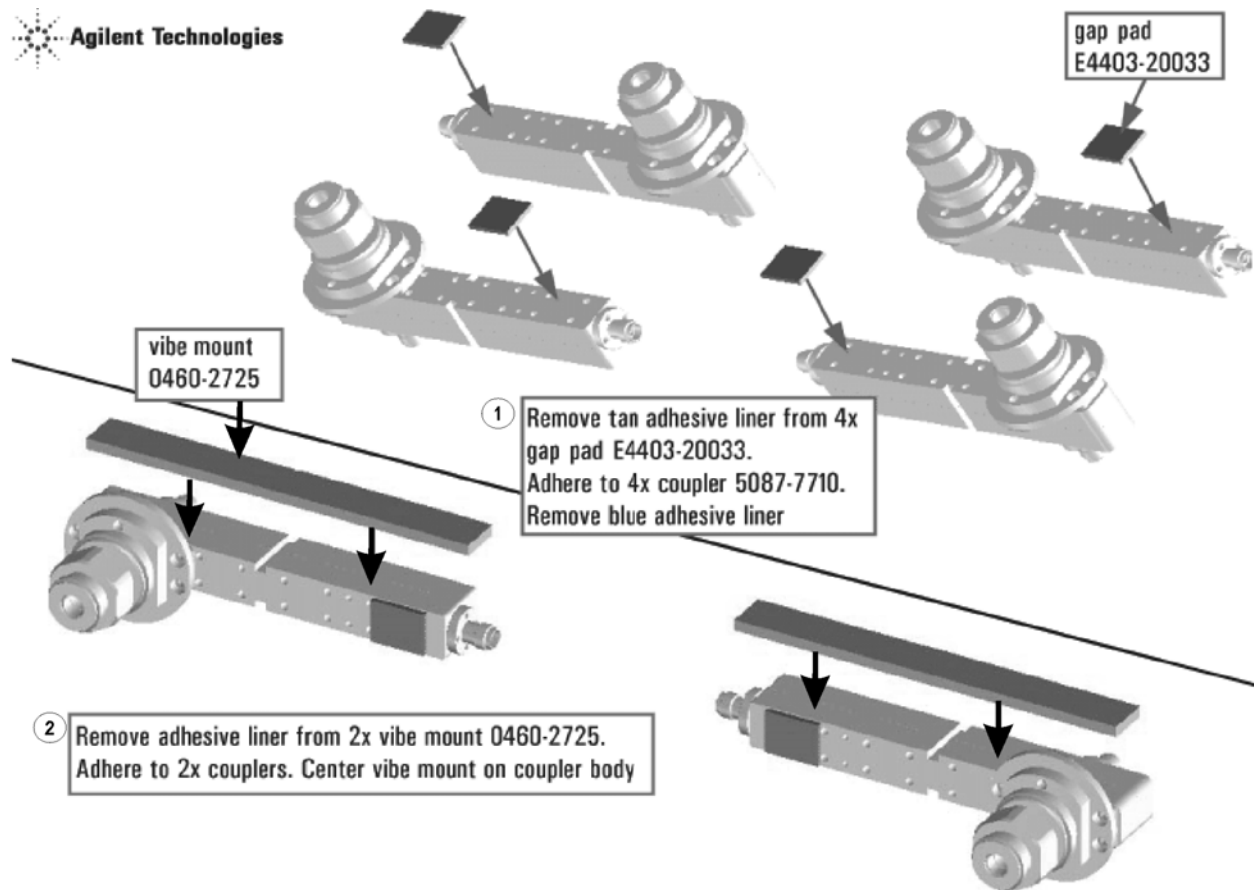

N5242_016_11

1. See “[Downloading the Online PNA Service Guide](#)” on page 5.

Step 14. Install the LED Boards and Test Port Coupler Assemblies to the Test Set Front Plate

1. Remove two screws from each LED board and remove the boards from the 2-port test set front plate of the PNA.
2. Remove the 2-port test set front plate from the test set deck.
3. Follow the two instructions shown in [Figure 8](#).

Figure 8 LED Board Assemblies and Test Port Coupler Assemblies Installation

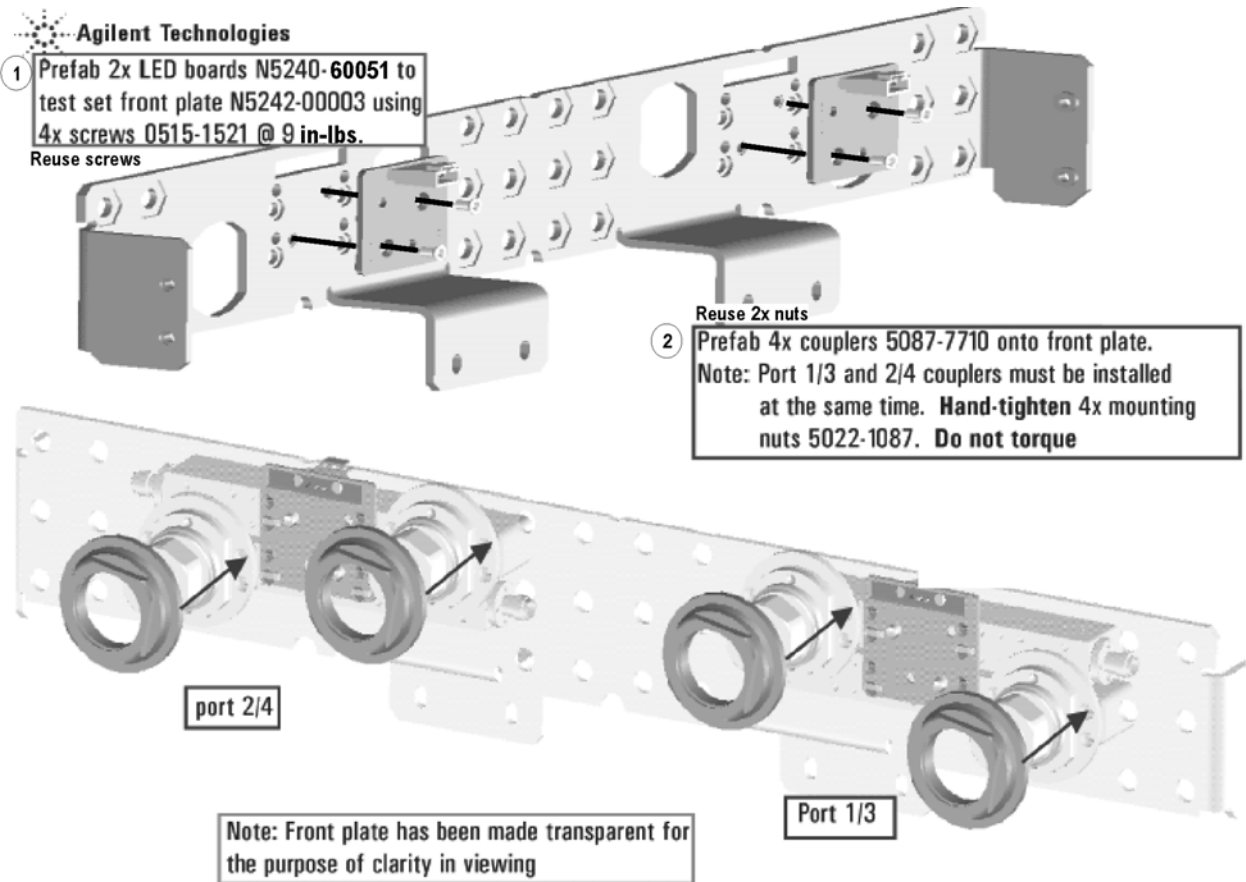

N5242_016_12

Step 15. Install the Coupler Plate Assembly to the Deck

Follow the four instructions shown in [Figure 9](#).

Figure 9 Coupler Plate Assembly Installation



Agilent Technologies

- Reuse screws
- 1 Install coupler plate assy to deck. Hand-tighten 4x screws 0515-0372. Do not torque.
 - 2 Reuse screws
Install 4x screws 0515-1227 @ 9 in-lbs.
Alternate sides in torque sequence.
 - 3 Torque the 4x screws in step 1 to 9 in-lbs.
 - 4 Torque 4x coupler mounting nuts to 72 in-lbs.

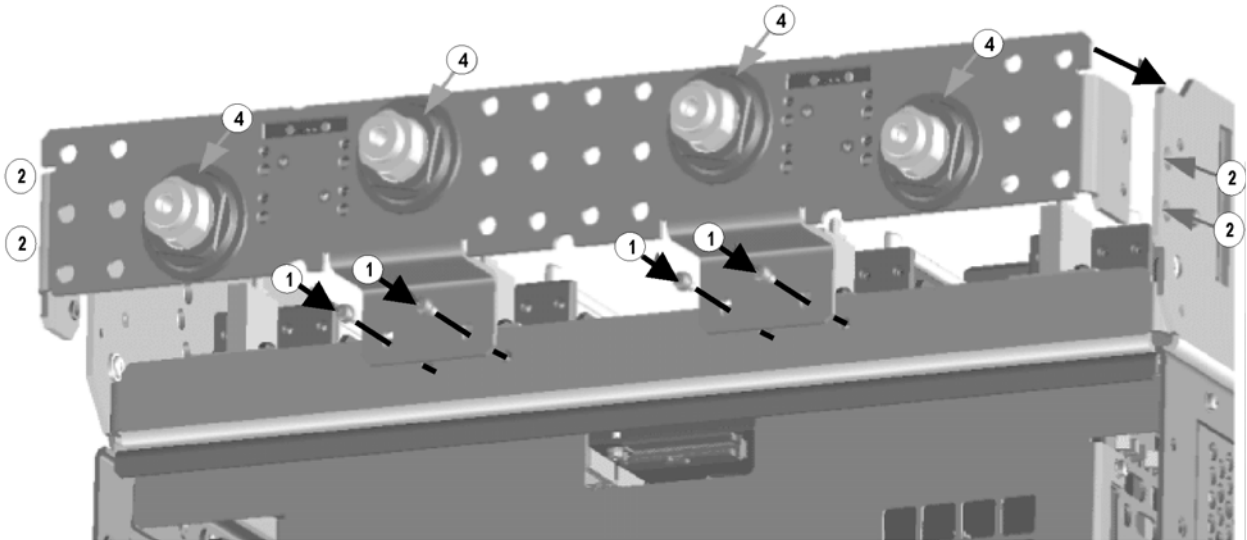

N5242_016_13

Step 16. Install the Second Source Boards

Install Cables on Source 2 Board

Refer to [Figure 10](#) of this document for this part of this step. New parts are listed in [Table 1](#) on [page 7](#) of this document.

1. Attach new cables W5 (N5242-20091) and W7 (N5242-20092) to the A8 26.5 GHz source 2 board as shown. Make sure that both cables are parallel to the A8 26.5 GHz source board as shown in the END VIEW. Cable W5 is the longer of the two cables.
2. Use a 5/16-in torque wrench set to 10 in-lbs to tighten the cable connectors.

Figure 10 Second Source Boards Installation, Part 1

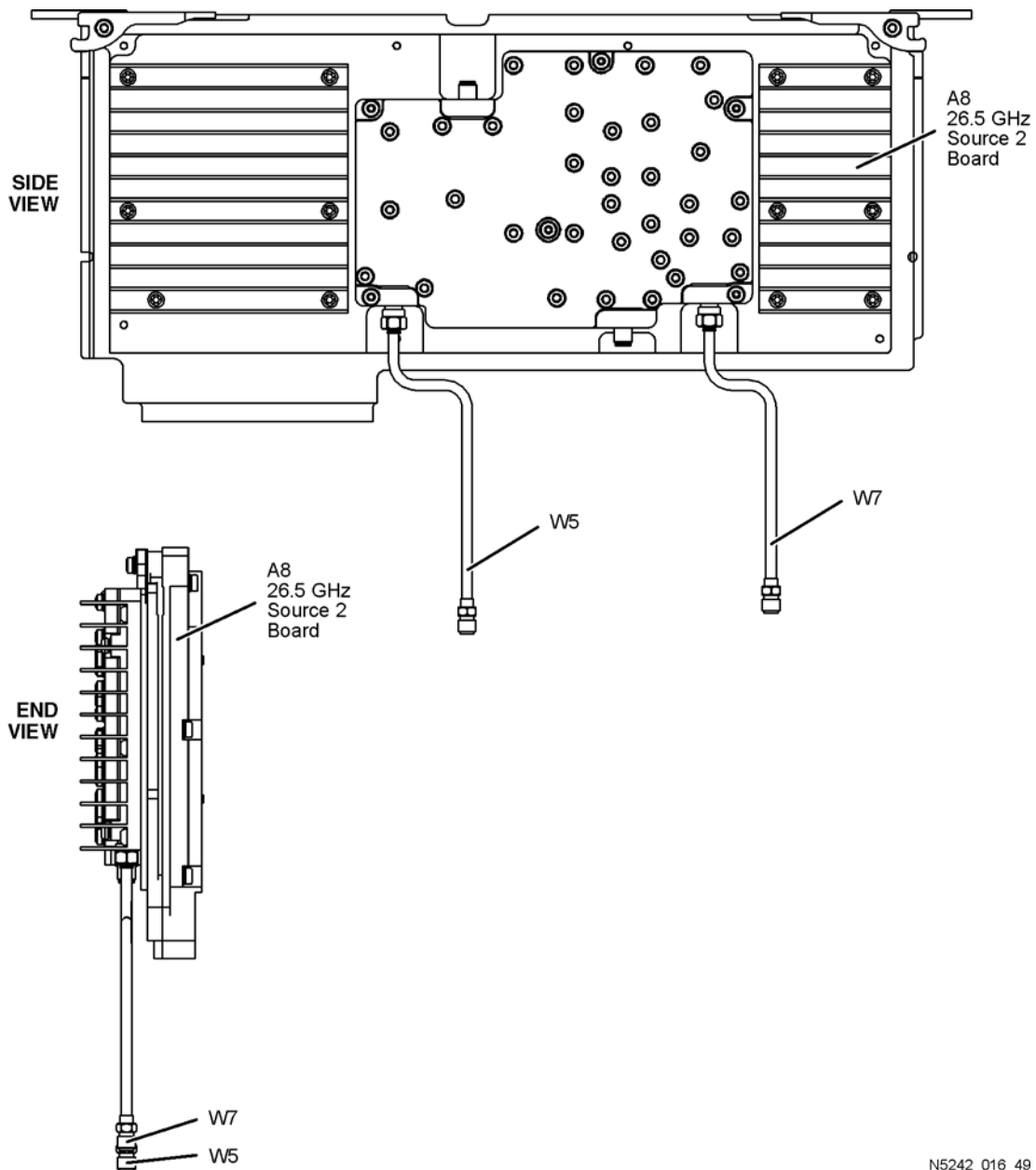

N5242_016_49

Install Cable on Source 2 Synthesizer Board

Install gray flex cable W67 (N5242-60030) to connector J5 of the Source 2 Synthesizer board. The loose end of the cable will be connected on the A10 frequency reference board (J7) after the Source 2 Synthesizer board has been installed in the analyzer.

Install the Second Source Boards into the Analyzer

Refer to [Figure 11](#) for this part of this step of the procedure. New parts are listed in [Table 1 on page 7](#).

1. Install the A8 26.5 GHz source 2 board (5087-7307) and the A13 13.5 GHz source 2 synthesizer board (N5230-60002) in the analyzer as shown. Secure the A8 26.5 GHz source 2 board with two screws (item ①; 0515-0380) and torque to 21 in-lbs.
2. Connect cable W2 (N5242-20124) between the A8 26.5 GHz source 2 board and the A13 13.5 GHz source 2 synthesizer board as shown. Be sure to position the cable in the wire looms as shown. Tighten the cable connectors to 10 in-lbs using a 5/16-in torque wrench.
3. Connect the loose end of gray flex cable W22 (N5242-60030) to the A10 frequency reference board (J7). (The other end of this cable was previously connected to J5 of the source 2 synthesizer board.)

Figure 11 Second Source Boards Installation, Part 3

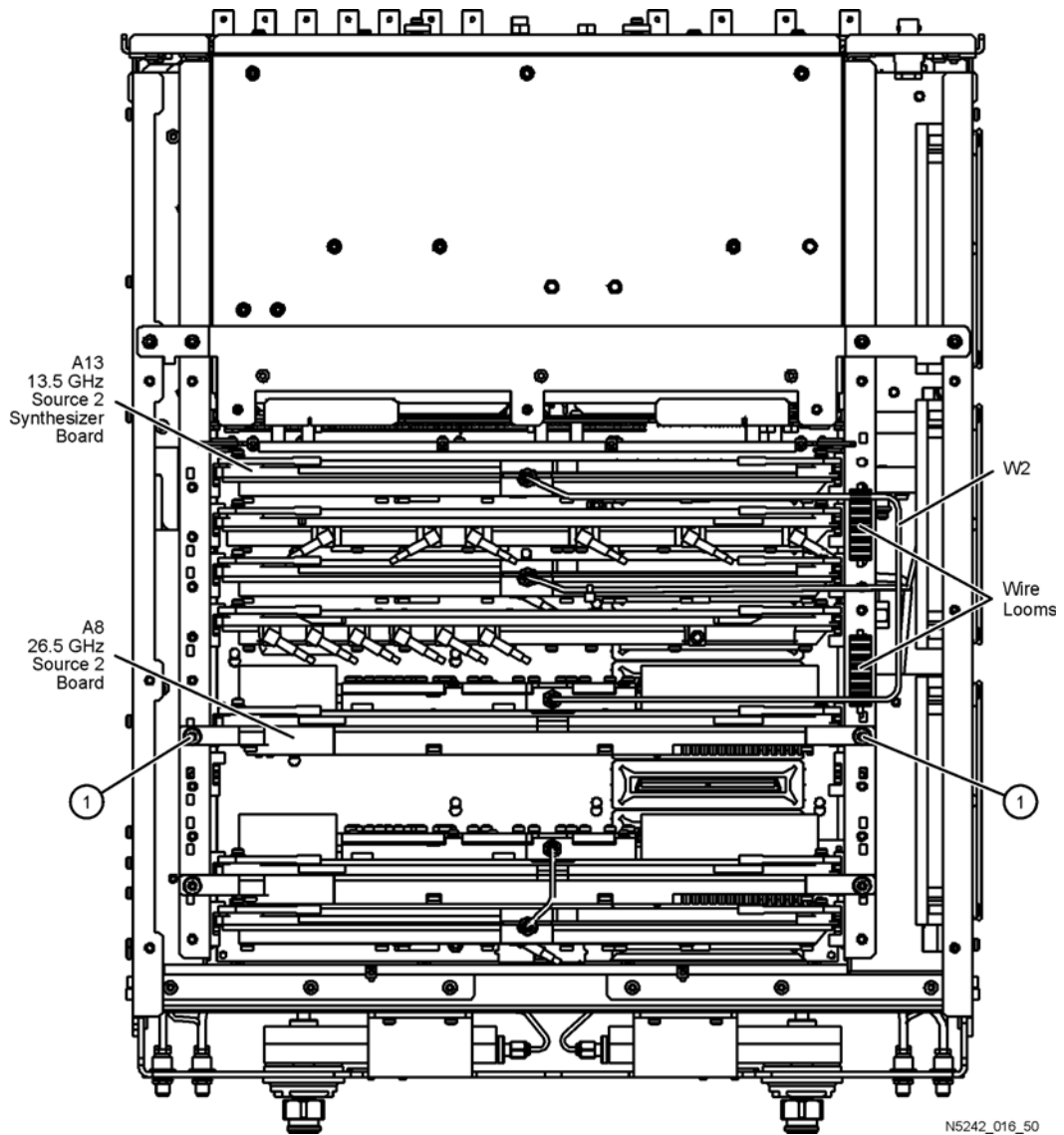

N5242_016_50

Step 17. Install the Test Set Cables

CAUTION Use a 5/16-in torque wrench set to 10 in-lbs on all cable connections except the front and rear panel cable connectors. Torque these connections to 21 in-lb.

1. Install the following semirigid cables in the order listed. To see images showing the location of these cables, click the Chapter 6 bookmark “Bottom RF Cables, 4-Port, Option 419” in the PDF Service Guide¹. New parts are listed in [Table 1 on page 7](#).
 - W26 (N5242-20044) A32 port 2 coupler to front-panel Port 2 CPLR ARM
 - W93 (reuse) (N5242-20047) Port 2 RCVR B IN to A45 port 2 receiver attenuator
 - W85 (reuse) (N5242-20045) Port 2 CPLR THRU to A41 port 2 bias tee
 - W84 (reuse) (N5242-20046) A37 port 2 source attenuator to front-panel Port 2 SOURCE OUT
 - W135 (reuse) (Opt 029 only) (N5242-20073) Front-panel Port 2 RCVR B IN to A45 port 2 receiver attenuator
 - W128 (reuse) (Opt 029 only) (N5242-20134) A53 port 2 bypass switch to front-panel Port 2 SOURCE OUT
 - W127 (reuse) (Opt 029 only) (N5242-20116) A37 port 2 source attenuator to A53 port 2 bypass switch
 - W130 (reuse) (Opt 029 only) (N5242-20133) A53 port 2 bypass switch to A54 port 2 bridge
 - W129 (reuse) (Opt 029 only) (N5242-20117) A53 port 2 bypass switch to A54 port 2 bridge
 - W86 (N5242-20023) A41 port 2 bias tee to A32 port 2 coupler
 - W91 (N5242-20032) Port 4 RCVR D IN to A44 port 4 receiver attenuator
 - W82 (N5242-20024) A40 port 4 bias tee to A31 port 4 coupler
 - W81 (N5242-20027) Port 4 CPLR THRU to A40 port 4 bias tee
 - W22 (N5242-20028) A31 port 4 coupler to front-panel Port 4 CPLR ARM
 - W80 (N5242-20030) A36 port 4 source attenuator to front-panel Port 4 SOURCE OUT
 - W39 (N5242-20037) REF 4 RCVR R4 IN to A24 mixer brick (R4)
 - W89 (N5242-20031) Port 3 RCVR C IN to A43 port 3 receiver attenuator
 - W74 (N5242-20022) A38 port 1 bias tee to A29 port 1 coupler
 - W77 (N5242-20026) Port 3 CPLR THRU to A39 port 3 bias tee
 - W18 (N5242-20025) A30 port 3 coupler to front-panel Port 3 CPLR ARM
 - W76 (N5242-20029) A35 port 3 source attenuator to front-panel Port 3 SOURCE OUT
 - W38 (N5242-20034) REF 3 RCVR R3 IN to A24 mixer brick (R3)

1. See [“Downloading the Online PNA Service Guide” on page 5](#).

- W14 (N5242-20040) A29 port 1 coupler to front-panel Port 1 CPLR ARM
- W87 (reuse) (N5242-20041) Front-panel Port 1 RCVR A IN to A42 port 1 receiver attenuator
- W73 (reuse) (N5242-20039) Front-panel Port 1 CPLR THRU to A38 port 1 bias tee
- W72 (reuse) (N5242-20038) A34 port 1 source attenuator to front-panel Port 1 SOURCE OUT
- W125 (reuse) (Opt 029 only) (N5242-20126) A52 port 1 bypass switch to A38 port 1 bypass tee
- W132 (reuse) (Opt 029 only) (N5242-20072) Front-panel Port 1 RCVR A IN to A42 port 1 receiver attenuator
- W124 (reuse) (Opt 029 only) (N5242-20125) Front-panel Port 1 CPLR THRU to A52 port 1 bypass switch
- W123 (reuse) (Opt 029 only) (N5242-20127) A52 port 1 bypass switch to front-panel Port 1 SOURCE OUT
- W78 (N5242-20021) A39 port 3 bias tee to A30 port 3 coupler

* Loosen 3x screws on A33 Reference Mixer Switch board, then slide the board to the rear of the instrument to connect the following two cables (N5242-20042 and N5242-20043).

- W36 (reuse) (N5242-20042) Front-panel REF 1 RCVR R1 IN to A33 reference mixer switch
- W35 (reuse) (N5242-20043) A33 reference mixer switch to front-panel REF 1 SOURCE OUT
- W122 (reuse) (Opt 029 only) (N5242-20128) A34 port 1 source attenuator to A52 port 1 bypass switch
- W83 (reuse) (N5242-20002) A28 port 2 bridge to A37 port 2 source attenuator
- W25 (reuse) (N5242-20048) A28 port 2 bridge to front-panel REF 2 SOURCE OUT
* Secure W25 to side of deck with 1x tie wrap (1400-0249)
- W126 (reuse) (Opt 029 only) (N5242-20066) A28 port 2 bridge to A37 port 2 source attenuator
- W137 (reuse) (Opt 029 only) (N5242-20074) A28 port 2 bridge to front-panel REF 2 SOURCE OUT
- W79 (N5242-20002) A27 port 4 bridge to A36 port 4 source attenuator
- W75 (N5242-20005) A26 port 3 bridge to A35 port 3 source attenuator
- W17 (N5242-20033) A26 port 3 bridge to front-panel REF 3 SOURCE OUT
- W21 (N5242-20035) A27 port 4 bridge to front-panel REF 4 SOURCE OUT

* Use 1/4" wrench to hold source cable connectors when tightening mating semi-rigid cables

- W10 (reuse) (N5242-20053) W9 to A28 port 2 bridge

- W8 (N5242-20052) W7 to A27 port 4 bridge
- W90 (N5242-20012) A43 port 3 receiver attenuator to A24 mixer brick (C)
- W71 (reuse) (N5242-20005) A25 port 1 bridge to A34 port 1 source attenuator
- W46 (reuse) (N5242-20090) W45 to rear-panel EXT TSET DRIVE RF OUT (J6)
- W4 (reuse) (N5242-20050) W3 to A25 port 1 bridge
- W121 (reuse) (Opt 029 only) (N5242-20067) A25 port 1 bridge to A34 port 1 source attenuator
- W6 (N5242-20051) W5 to A26 port 3 bridge
- W37 (reuse) (N5242-20009) A33 reference mixer switch to A23 mixer brick (R1)
 - * Secure W37 to side of deck with 3x tie wrap (1400-0249)
- W88 (reuse) (N5242-20010) A42 port 1 receiver attenuator to A23 mixer brick (A)
- W13 (reuse) (N5242-20011) A25 port 1 bridge to A33 reference mixer switch
- W136 (reuse) (Opt 029 only) (N5242-20068) A33 reference mixer switch to A23 mixer brick (R1)
- W133 (reuse) (Opt 029 only) (N5242-20069) A42 port 1 receiver attenuator to A23 mixer brick (A)
- W94 (reuse) (N5242-20016) A45 port 2 receiver attenuator to A23 mixer brick (B)
- W92 (N5242-20036) A44 port 4 receiver attenuator to A24 mixer brick (D)
- W40 (reuse) (N5242-20049) Front-panel REF 2 RCVR R2 IN to A23 mixer brick (R2)
- W134 (reuse) (Opt 029 only) (N5242-20070) A45 port 2 receiver attenuator to A23 mixer brick (B)
- W138 (reuse) (Opt 029 only) (N5242-20075) Front-panel REF 2 RCVR R2 IN to A23 mixer brick (R2)
- W43 (N5242-20013) A22 splitter to A23 mixer brick
 - * Leave the W43 loose for now.
- W44 (N5242-20014) A22 splitter to A24 mixer brick
 - * Leave the W44 loose for now.
- W42 (N5242-20015) A21 HMA26.5 to A22 splitter
 - * Leave the W42 loose for now.
- * Tighten 2x screws on A22 splitter @ 9 in-lbs.
 - * Tighten cable nuts on W42, W43, and W44 @10 in-lbs.
- W140 (Opt 029 only) (N5242-20118) A24 mixer brick to A55 noise downconverter
- W47 (reuse) (N5242-20089) A23 mixer brick to rear-panel EXT TSET DRIVE LO OUT (J5)
- W41 (reuse) (N5242-20110) A11 13.5 GHz synthesizer to A21 HMA26.5
 - * Route cable through deck cutout to A11 synthesizer board.
- W30 (reuse 6x) (E8356-20072) Front panel jumpers

Step 18. Secure the Front Panel Bulkhead Connectors

Follow the instruction shown in [Figure 12](#) in this document.

Figure 12 Bulkhead Connections, Front Panel



- ① Secure 24x hex nuts on the front panel bulkhead connectors to 21 in-lbs using a 5/16" nut bit and pneumatic driver

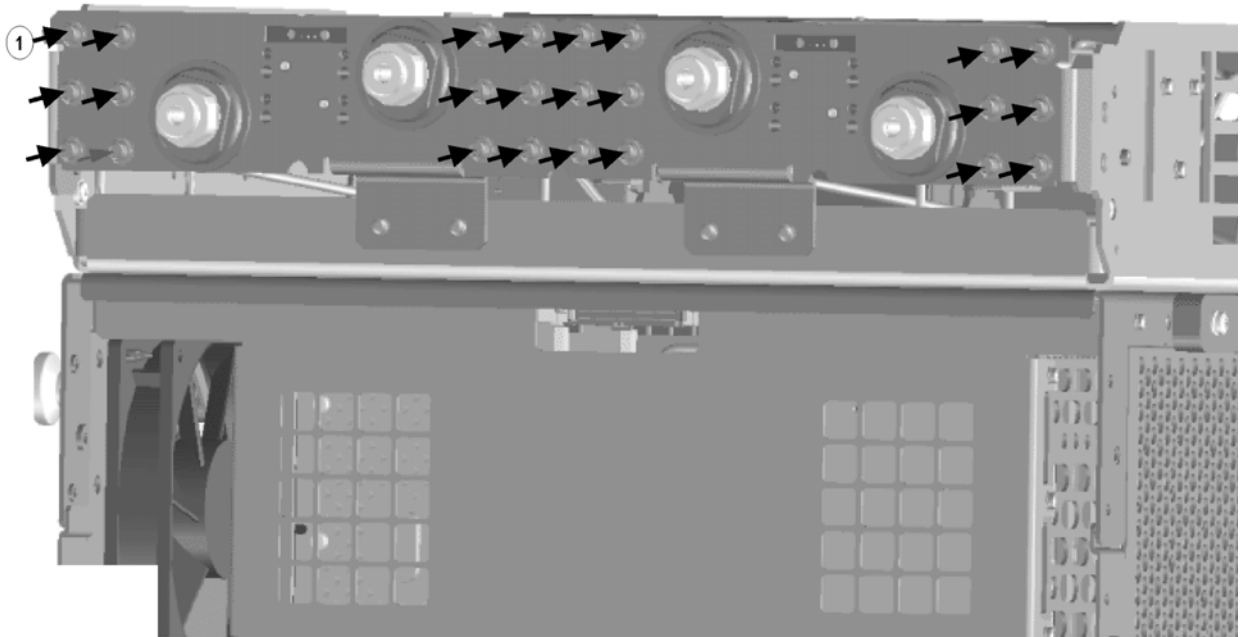

N5242_016_31

Step 19. Reinstall the A19 Test Set Motherboard

1. For instructions on reinstalling the board, click the Chapter 7 bookmark “Removing and Replacing the A19 Test Set Motherboard” in the PDF Service Guide¹.
2. Install the following new ribbon cables in the order listed. To see an image showing the location of these cables, click the Chapter 6 bookmark “Bottom Ribbon Cables and Wire Harnesses, 4-Port, Option 419 (including Option 029)” in the PDF Service Guide¹. New parts are listed in [Table 1 on page 7](#).
 - Ribbon cable, N5242-60006 from J213 to A24 mixer brick (2)
 - Ribbon cable (part of bias tee assembly), port 3 bias tee to A19 test set motherboard J543
 - Ribbon cable (part of bias tee assembly), port 4 bias tee to A19 test set motherboard J544
 - Ribbon cable (N5242-60007), A19 test set motherboard J206 to A43 port 3 receiver attenuator
 - Ribbon cable (N5242-60007), A19 test set motherboard J207 to A44 port 4 receiver attenuator
 - Ribbon cable (N5242-60008), A19 test set motherboard J202 to A35 port 3 source attenuator
 - Ribbon cable (N5242-60008), A19 test set motherboard J203 to A36 port 4 source attenuator

Step 20. Replace the 2-Port Front Frame with a 4-Port Front Frame

Before the front frame can be replaced, the items making up the back side of the front panel assembly must be removed. For instructions on removing these items, click the Chapter 7 bookmark “[Removing and Replacing the A1-A3 and Other Front Panel Subassemblies](#)” in the PDF Service Guide¹. New parts are listed in [Table 1 on page 7](#).

1. In the section “[Removing the A2 USB Board](#),” perform step 1 (the only step).
2. In the section “[Removing the A1 Front Panel Interface Board and Keypad Assembly](#),” perform steps 1 - 5.
3. In the section “[Removing the Power Switch Board and Power Button Keypad](#),” perform only steps 1 and 2.
4. Remove the braided gasket from the backside edges of the 2-port front frame and install it in the 4-port front frame (N5245-20128).
5. Reassemble the front panel assembly with the new 4-port front frame (N5245-20128) by reversing the order of the instructions previously followed.

1. See “[Downloading the Online PNA Service Guide](#)” on page 5.

Step 21. Reinstall the Front Panel Assembly

For instructions on reinstalling the front panel assembly, click the Chapter 7 bookmark [“Removing and Replacing the Front Panel Assembly”](#) in the PDF Service Guide¹.

Step 22. Install the Front Panel Overlays

To see an image of the front panel overlay, keypad overlay, and power button overlay, click the Chapter 6 bookmark [“Front Panel Assembly, Front Side, All Options”](#) in the PDF Service Guide¹. New parts are listed in [Table 1 on page 7](#).

1. Remove the protective backing from the new front panel overlay (N5242-80003 for instruments without option 029 or N5242-80012 for instruments with option 029).
2. Loosely place the overlay in the recess on the front panel.
3. Placing two fingers at the middle, press the overlay firmly onto the frame while sliding your fingers in opposite directions towards the ends of the overlay. Repeat on all areas of the overlay.
4. Repeat steps 1-3 to install the keypad overlay (N5242-80005).
5. Repeat steps 1-3 to install the power button overlay (N5242-80007).
6. Repeat steps 1-3 to install the new nameplate (N5241-80001 for N5241A models or N5242-80006 for N5242A models).

Step 23. Install the Front Panel Jumper Cables

For instructions on installing the W30 front panel jumpers (E8356-20072), click the Chapter 7 bookmark [“Removing and Replacing the Front Panel Assembly”](#) in the PDF Service Guide¹.

Step 24. Reinstall the Inner Cover

For instructions, click the Chapter 7 bookmark [“Removing the Covers”](#) in the PDF Service Guide¹.

Step 25. Reinstall the Outer Cover

For instructions, click the Chapter 7 bookmark [“Removing the Covers”](#) in the PDF Service Guide¹.

Step 26. Install the Cable Guard

Push the cable guard over the six new front jumper cables until its cushioning material touches the front panel of the PNA.

Step 27. Enable Options P04 and 419

Procedure Requirements

- The analyzer must be powered up and operating to perform this procedure.
- The Network Analyzer program must be running.
- Obtain a license key for installation of this upgrade by following the instructions on the supplied Option Entitlement Certificate.

Option Enable Procedure

1. To start the option enable utility, press UTILITY **System**, then **Service**, then **Option Enable**. An option enable dialog box will appear.
2. Click the arrow in the **Select Desired Option** box. A list of available options will appear.
3. In the **Select Desired Option** list, click **P04 - 4-Ports**.
4. Using the keyboard, enter the license key in the box provided. The license key is printed on the license message you received from Agilent. Enter this key *exactly* as it is printed on the message.
5. Click **Enable**.
6. Click **Yes** in answer to the displayed question in the **Restart Analyzer?** box.
7. Repeat steps 3-6 to enable Option 419, clicking **419 - Src/Rcvr Atten & Bias Ts 4-Port** in step 3.
8. When the installation is complete, click **Exit**.

Option Verification Procedure

Once the analyzer has restarted and the Network Analyzer program is again running:

1. On the analyzer's **Help** menu, click **About Network Analyzer**.
2. Verify that "P04" and "419" are listed after "Options:" in the display. Click **OK**.

NOTE If the options have not been enabled, perform the ["Option Enable Procedure"](#) again. If the options are still not enabled, contact Agilent Technologies. Refer to ["Getting Assistance from Agilent" on page 3](#).

Step 28. Perform Post-Upgrade Adjustments and Calibration

Adjustments

The following adjustments must be made due to the hardware changes of the analyzer.

- default EE
- source adjustment
- receiver adjustment

These adjustments are described in the PNA Service Guide and in the PNA on-line HELP. A list of equipment required to perform these adjustments is also found in the service guide.

After the specified adjustments have been performed, the analyzer should operate and phase lock over its entire frequency range.

Operator's Check

Perform the Operator's Check to check the basic functionality of the analyzer. For instructions, click the Chapter 3 bookmark "Tests and Adjustments" in the PDF Service Guide¹.

If you experience difficulty with the basic functioning of the analyzer, contact Agilent. Refer to ["Contacting Agilent" on page 3](#).

Calibration

Although the analyzer functions, its performance relative to its specifications has not been verified. It is recommended that a full instrument calibration be performed using the analyzer's internal performance test software. To view information on the performance test software, click the Chapter 3 bookmark "Tests and Adjustments" in the PDF Service Guide¹.

1. See ["Downloading the Online PNA Service Guide" on page 5](#).